



SBR 1100

Banco di bloccaggio per saldatura 1100 mm di lunghezza.

Tubo di appoggio con barra di supporto in lega di rame; la barra, disponibile con raffreddamento ad acqua, può essere fornita con fori di insufflaggio gas. Centratore longitudinale pneumatico. Gli SBR sono forniti in versione Tig, Mig o arco sommerso.

Longitudinal seam welding positioner; models 1100 mm. of welding length. Support pipe incorporating copper alloy back-up bar Available with gas inlet holes and water cooled. Pneumatically operated longitudinal alignment device. SBR positioners are available in Tig, Mig or sub-merged arc version.

Banc de blocage pour soudage 1100 mm de longueur. Tube d' appui avec baguette de support en alliage de cuivre; la baguette, disponible avec refroidissement à eau, peut être fournie avec des trous d' insufflation du gaz. Centreur longitudinal pneumatique. Les SBR sont fournis dans les modèles Tig, Mig ou à l' arc submergé.

Längsnahtschweißvorrichtung für Schweißungen 1100 mm Länge. Auflagerrohr mit Halterungsstange aus Kupferlegierung; die Stange, die auch mit Wasserkühlung lieferbar ist, kann mit Bohrungen für das Formieren geliefert werden. Pneumatische Zentriervorrichtung in Längsrichtung. Die SBR werden in den Ausführungen Tig, Mig oder für Unterpulverschweißung geliefert.

Banco de bloqueo para soldar 1100 mm de longitud. Tubo de apoyo con barra de soporte en aleación de cobre; la barra, disponible con refrigeración por agua, puede ser suministrada con agujeros de insuflación de gas. Centrador longitudinal neumático. Los SBR son suministrados en versión Tig, Mig o arco sumergido.

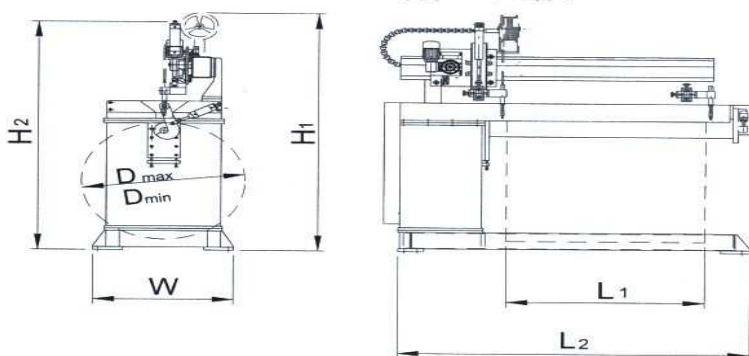

SBR 1100
L1 mm = 1100
Dmin mm = 160
Dmax mm = 800
mm/1' = 150-3000
L2 mm = 2170
W mm = 1000
H1 mm = 1800
Kg/m = 1000

mm = 0.8-3
Volt = 1x230
Volt = 24
L2xWxH2 mm = 2170x1000x2200
Kg = 1500

ITEM	DESCRIPTION	PRICE CHF
SBR 1100	Longitudinal seam welding positioner. Welding length 1100 mm.; Standard diameter of part to be welded: min. 160 mm., max 800 mm. Thickness od weldable coil standard: min. 0,8 mm., max 3 mm.	Mig version: 64505.00 TIG/Plasma version: 66880.00
SBR/SBA	Non-magnetic bearing bar	1550.00
SBR/GRB	Cooling bar group	1805.00
SBR/IGPS	Welding protection gas input (Tig and Plasma)	1235.00
SBR/AFF	Cold wire feed (Tig)	8740.00
SBR/AVC	AVC torch length sensor (Tig and Plasma)	16150.00
SBR/SVRM	Manual adjusting ferrule bearing	4180.00
SBM/SBRO	Oleo dynamic adjusting ferrule bearing	12255.00
SBR/RBRT	Copper bar spare part Tig-Plasma	1615.00
SBR/RBRM	Copper bar spare part Mig and SubArc	1425.00

Common technical characteristics: electro-welded frame made by steel; back-up mandrel with Cu-Cr-Zr back-up bar; predisposition for back-up bar cooling; Travelling car including torch support with pneumatic control; pneumatic front side mandrel lock; pneumatic longitudinal alignment device; control panel.