



# SPS 150 HC

Posizionatore a tavola rotante portata 150 Kg.  
Rotazione con motore auto-frenante a corrente continua, riduttore a vite senza fine e ralla a sfere.  
Inclinazione manuale con foro passante Ø 100 mm.

Turntable type positioner maximum load 150 Kg. Slewing by DC selfbraking motor through worm and ball slewing ring. Tilt: manual.

Positionneur à table rotative portée 150 Kg. Rotation avec moteur automaintenu à courant continu, réducteur à vis sans fin et butée à billes. Inclinaison manuelle.

Drehtisch-Positionervorrichtungen Tragkraft 150 Kg.  
Rotation mit selbstbremsenden Gleichstrommotor, Endlosschneckenuntersetzung und Kugelscheibe. Schwenkung manuell.

Posicionadores de mesa giratoria portal 150 Kg. Rotación por motor freno de corriente continua, reductor de tornillo sin fin y rangua de bolas. Inclinaçión manual.

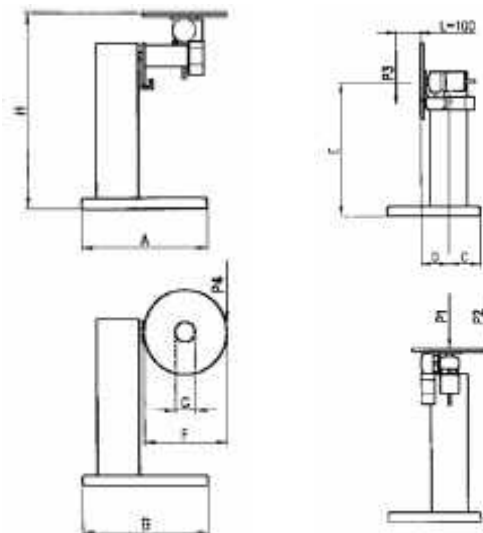

SPS 150 HC
A = 700
B = 700
C = 200
F diam mm = 500
E = 730
D = 200
H = 910
Volt = 220
RPM = 0,5 – 9
P1 Kg = 150
P2 Kg = 80
Mf Kgm = 10
P3 Kg = 110
P4 Kg = 45
Mt Kgm = 10
PESO Kg/Weight = 132

ITEM	DESCRIPTION	PRICE CHF
SPS 150 HC	Turntable positioner for bench use. Manual tilt. Max acceptable load 150 Kg (330Lbs)	7600.00

#### ACCESSORIES

SPS/TT	Table delayed start device for TIG welding	798.00
SPS/SCH	Hi-frequency shielding	570.00
SPS/ML	Display LCD	608.00
SP/TF	Crater filler device for TIG/WIG welding	912.00

#### LEGEND

SPS	Turntable positioner, standard version
SPS ... S	Turntable positioner with overwelding function and single control for slewing and welding power source start
SPS ... HC	Turntable positioner with 100 mm. hollow centre turntable
SPS ... S HC	Turntable positioner with overwelding function, single control for slewing & welding power source start and hollow centre turntable

Packaging : wooden crate surcharge CHF 42.00 net